



Features overview

ARM7TDMI™ ARM Thumb processor core

- High performance 32-bit RISC
- High Density 16-bit Instruction Set Architecture (Thumb)
- Embedded ICE

32 Kbytes Internal RAM

1 Mbytes Internal Program Flash

32 Kbyte Internal Data Flash

- EEPROM emulation
- Isolated block

Lite Direct Memory Access (LDMA)

- 8 channels
- peripherals ↔ memories transfers
- memory ↔ memory transfers

External Protocol Controller (EPC)

- 2 to 16 bit parallel data
- 128 Mbytes addressable

Clock generator with configurable PLL

16-level priority, Generic Interrupt Controller

- 12 external interrupt lines

3x16-bit General Purpose Timer (GPT)

- 3 configurable modes: counter, PWM, capture
- 3x16-bit capture/compare

8x16-bit Simple Timer (ST)

- 4 channels on peripheral clock
- 4 channels on Low frequency clock
- autoreload

16-bit Stamp timer (STT)

- CAN messages stamp on low frequency clock

16-bit Programmable Watchdog (WD)

16-bit Capture Modules (CAPT)

- 1 DMA channels

2 I²C Modules (I2C)

- 400Kbit/s in fast mode & 100Kbit/s in normal mode

6 Stepper Motor Controller (SMC)

- normal/wave/halfstep/microstepping mode
- microstepping cosinus/sinus & high torque

LCD controller (LCDC)

- 4 x 40 segment
- static, 1/2 & 1/3 bias

14 Pulse Width Modulation (PWM)

- 12 channels x 8-bit and 2 channel 16-bit counter

4 CAN controllers certified 2.0A and 2.0B full speed

- 32 buffers each
- Stampable message

3 UART-LIN

- Full LIN 1.2 and 2.0 hardware support
- 5 to 9-bits data length
- J1587 protocol support
- 1 UART with synchronous transfer support
- 3 DMA channel

2 Master/Slave Serial Port Interface (SPI)

- 1 SPI 1 to 8 bit programmable data length
- 1 SPI 8 to 16-bit programmable data length
- 4 channel DMA

16 channel 10-bit Analog/Digital Converters (ADC)

- 16 analog inputs.
- 1 DMA channel
- 500KSps
- 1 conversion register per channel

Clock Manager (CM)

- Internal ring oscillator @1MHz control
- Phased-Locked Loop control (PLL)
- Peripheral and CPU clock gating control
- Power-Mode control :
 - Idle mode: only CPU clock stop
 - Normal and High speed mode
 - Stop mode: selected clocks stop
 - Sleep/Lowpower Modes
- Clock monitor

101 multiplexed GPIO

Power On Reset (POR)

Low Voltage Detector (LVD)

- Interrupt and reset generation

Fully Static Operation: 0Hz to 40MHz

- Only 5V supply for Core and IOs
- 3.0~5.5V IOs
- -40° to +105°C Operating Temperature Range

144-lead free LQFP Package

AEC-Q100 qualification

Mass production released



Block diagram

The easyCAN4F belongs to the easyCAN product family. The easyCAN family is supported by a platform of tools and product that includes:

- A development tool based on Scaleo chip FCM3 enabling accurate prototyping, emulation and validation
- Micro Controller Abstraction Layer 2.1 (MCAL) software

The easyCAN4F is based on an ARMTDMI™ embedded processor that combines the high performance of a 32-bit RISC together with the high code density of its 16-bit instruction and a very low power consumption.

The easyCAN4F embeds all necessary RAM and Flash memories for maximum performance with an optimised system cost.

Real-time software is efficiently handled thanks to a collection of sophisticated peripheral modules.

The device is manufactured using high density CMOS technology. By combining ARMTDMI™ core with on-chip RAM, Flash and a wide range of peripheral functions on a monolithic chip, the Scaleo chip easyCAN4F is a powerful microcontroller that provides a flexible, cost effective solution to compute-intensive embedded control applications in the automotive and industrial world.

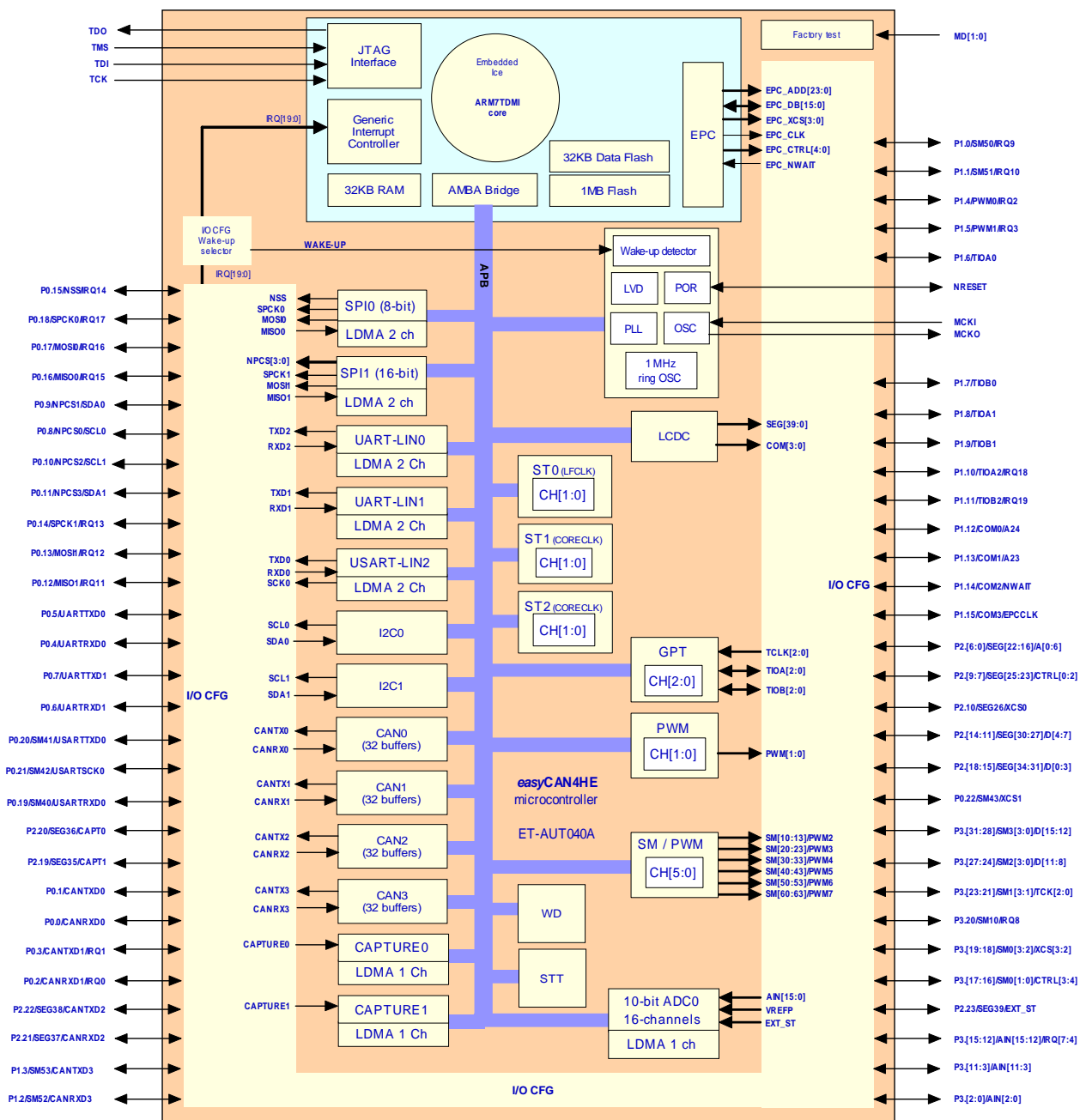



easyCAN4 F1M-32

Automotive Microcontroller



Product Brief

AUTOSAR MCAL package

Scaleo chip offers AUTOSAR Micro-controller Abstraction Layer (MCAL) software conforming to the AUTOSAR R2.1 standard. Thanks to its knowhow on its automotive silicon product Scaleo chip develops optimized MCAL software to enable the best hardware features utilization.

Scaleo chip MCAL AUTOSAR R2.1 package:

- Optimized MCAL, enabling all hardware resources.
- CMMI level 3 development process.
- Software MCAL code source
- AUTOSAR template files
- Software MCAL datasheet
- Software MCAL test specification and criteria
- Software unitary tests
- Software Integration tests
- Software MCAL test reports

